



SuperVue Series

960H | 700TVL | TRUE D&N
ICR

Features

- SuperVue 960H CCD
- Ultra High Resolution 700TVL
- Built-in 2.8 ~ 12mm Varifocal lens with auto iris
- 36 IR Leds (Select models only:VKR-V355)
- ICR, DWDR, 3DNR, Sense-up, OSD
- Smoked Vandal proof Dome
- Dual Voltage (24V AC / 12V DC)
- Waterproof(IP68)

Dimensions

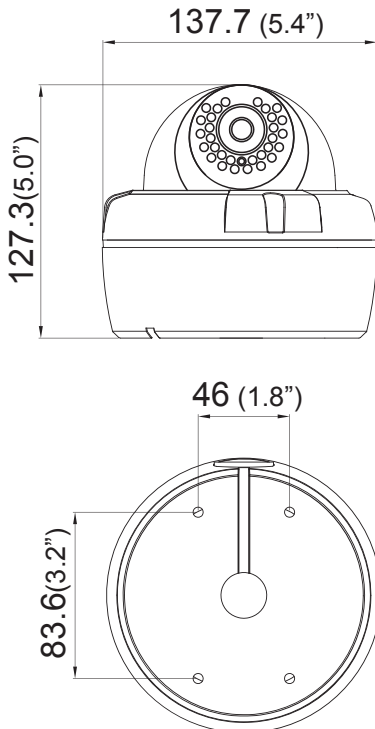

Specifications

MODEL	VKN-V355	VKR-V355
IMAGE SENSOR	1/3" 960H IT CCD	
EFFECTIVE PIXEL	976(H) x 494(V)	
SCANNING SYSTEM	2:1 INTERLACE	
SYNCHRONIZATION	INTERNAL	
HORIZONTAL RESOLUTION	700TV LINES	
VIDEO OUTPUT	COMPOSITE (1.0Vp-p/75Ohm)	
S/N (Y SIGNAL)	52dB (AGC OFF)	
LENS	2.8~12mm DC Auto Iris Lens (ICR)	
ELECTRONIC SHUTTER	1/60 ~ 120,000sec	
BACKLIGHT COMPENSATION	BLC / HSBLC / OFF	
WHITE BALANCE	ATW / PUSH / USER1 / USER2 / ANTI CR / MANUAL / PUSH LOCK	
DAY & NIGHT	COLOR / AUTO / B/W / EXT1 / EXT2	
PRIVACY MASKING	ON/OFF (8 ZONES)	
DNR	OFF / LOW / MIDDLE / HIGH	
SMART IR	OFF / ON	
SENS UP	OFF / x1 ~ x512	
MOTION	OFF / ON (4 POINTS)	
DEFECT DET	OFF / ON	
IR LED	-	36 IR Leds
INPUT VOLTAGE	DC 12V(±10%) / AC 24V DUAL VOLTAGE	
HEATER OPERATION SPECIFICATION	INTERNAL OPERATING TEMPERATURE OFF : 20° / ON : -20°	
POWER CONSUMPTION	HEATER OFF DC IR OFF : 140mA(±10%) / IR ON : 360mA (Max)	
	HEATER OFF AC IR OFF : 220mA(±10%) / IR ON : 400mA (Max)	
	HEATER ON DC IR OFF : 260mA(±10%) / IR ON : 480mA (Max)	
	HEATER ON AC IR OFF : 350mA(±10%) / IR ON : 500mA (Max)	
OPERATING TEMP/ HUM	-10°C ~ +50°C / MAX 90% RH	
STORAGE TEMP/ HUM	-20°C ~ +60°C / MAX 90% RH	